

Aluminium Tripod Crane

Load capacity 500 kg, 1.000 kg, 2.000 kg, 3.000 kg

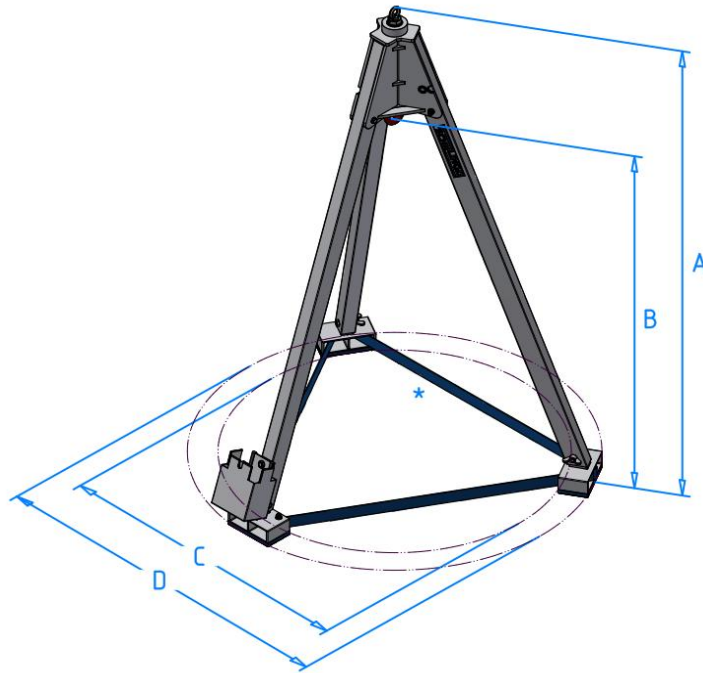

item no.	load capacity	total height		suspension point		internal diameter in assembled state		external diameter in assembled state		transport height	transport diameter	weight
		min.	max.	min.	max.	min.	max.	min.	max.			
		A		B		C		D				
	kg	mm	mm	mm	mm	mm	mm	mm	mm	mm	mm	kg
500 kg												
1620500	500	2061	3490	1657	3085	1383	2422	1638	2672	2182	Ø485	57
1.000 kg												
1621000	1000	2061	3490	1657	3085	1383	2422	1638	2672	2182	Ø485	57
1621001	1000	2192	3620	0	3120	1383	2422	1638	2672	2312	705x485	80
1621002	1000	2853	3680	0	3120	1820	2422	2072	2672	3086	808x841	173
2.000 kg												
1622000	2000	2063	3492	1647	3075	1383	2422	1638	2672	2184	Ø485	59
3.000 kg												
1623000	3000	2143	3571	1636	3065	1383	2499	1638	2758	2263	Ø485	63

* incl. lashing strap: The adjustable feet are connected; this provides additional stability

1) Model with manual winch



2) Model with electric winch

